

# BVM MANUAL TONG SPECIFICATIONS

BVM Tongs are constructed from the finest alloy steel, all machined surfaces are held to a close tolerance. All parts are heat treated for maximum strength and a magnetic particle inspection is performed to detect cracks in the metal. All BVM's Tongs are tested for performance before shipping. BVM Tong dies are made from carburized alloy steel and are heat treated for extreme hardness and strength. Tong size are available to cover drill pipe and casing sizes from 1.900" OD, through 30" OD, torque rating will vary with the size of lug jaw used. (BVM Tongs are interchangeable with most major brands).

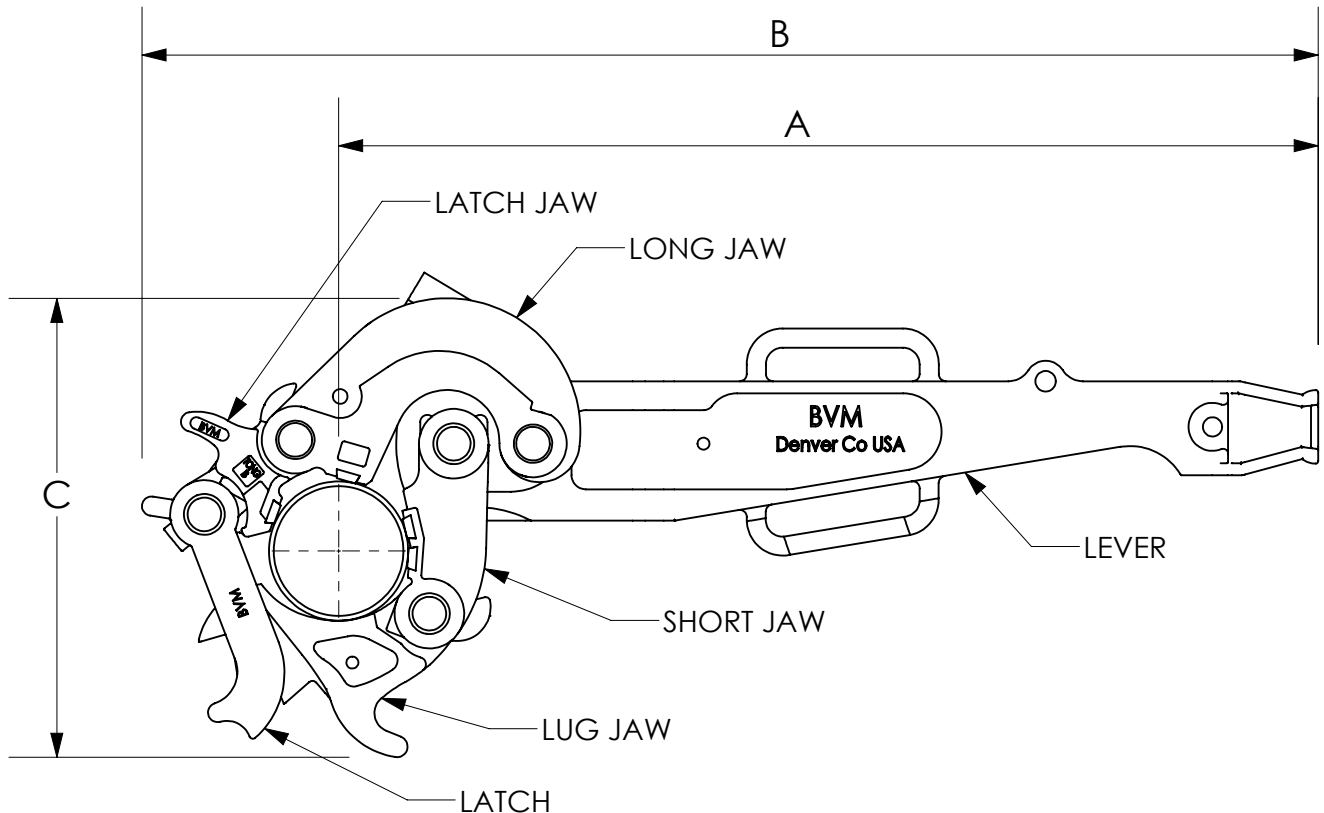

## DIMENSIONAL DATA

BVM TONG TYPE	LEVER	A Max	B Max	C Max	TORQUE ft/lbs	SIZE
"SDD"	Standard	60"	78"	34 1/8"	100,000	4" - 17"
"H"	50"	51 1/2"	68"	30"	80,000	3 1/2" - 13 3/8"
"DB"	Standard	59 9/16"	72 9/16"	35 3/4"	65,000	3 1/2" - 17"
"B"	Long	55 3/16"	66 7/16"	23 1/4"	55,000	3 1/2" - 13 3/8"
"B"	Short	49 3/16"	60 7/16"	23 1/4"	42,000	3 1/2" - 13 3/8"
"B" Ext	Standard	---	---	---	25,000	13 3/8" - 30"
"AAX"	48"	55 1/2"	67 1/2"	25"	55,000	2 7/8" - 13 3/8"
"AAX"	42"	48"	60 1/2"	25"	55,000	2 7/8" - 13 3/8"
"AAX"	36"	42 1/2"	55"	25"	55,000	2 7/8" - 13 3/8"
"C"	Long	47 1/8"	57 1/8"	18"	35,000	2 3/8" - 10 3/4"
"C"	Short	36 3/16"	46 3/16"	18"	35,000	2 3/8" - 10 3/4"
"LF"	Standard	27"	33"	14"	16,000	2 3/8" - 8 5/8"
"MS"	Standard	28 3/4"	33 3/4"	8"	6,500	1.900" - 6 1/8"