

BVM G SERIES ELEVATOR

Elevators are produced from cast alloy heat treated steel and have a working capacity of 100, 150, 175, 250, 350 and 500 Tons - depending on the model.

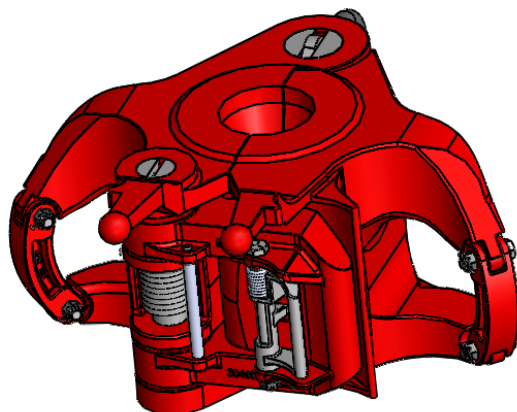
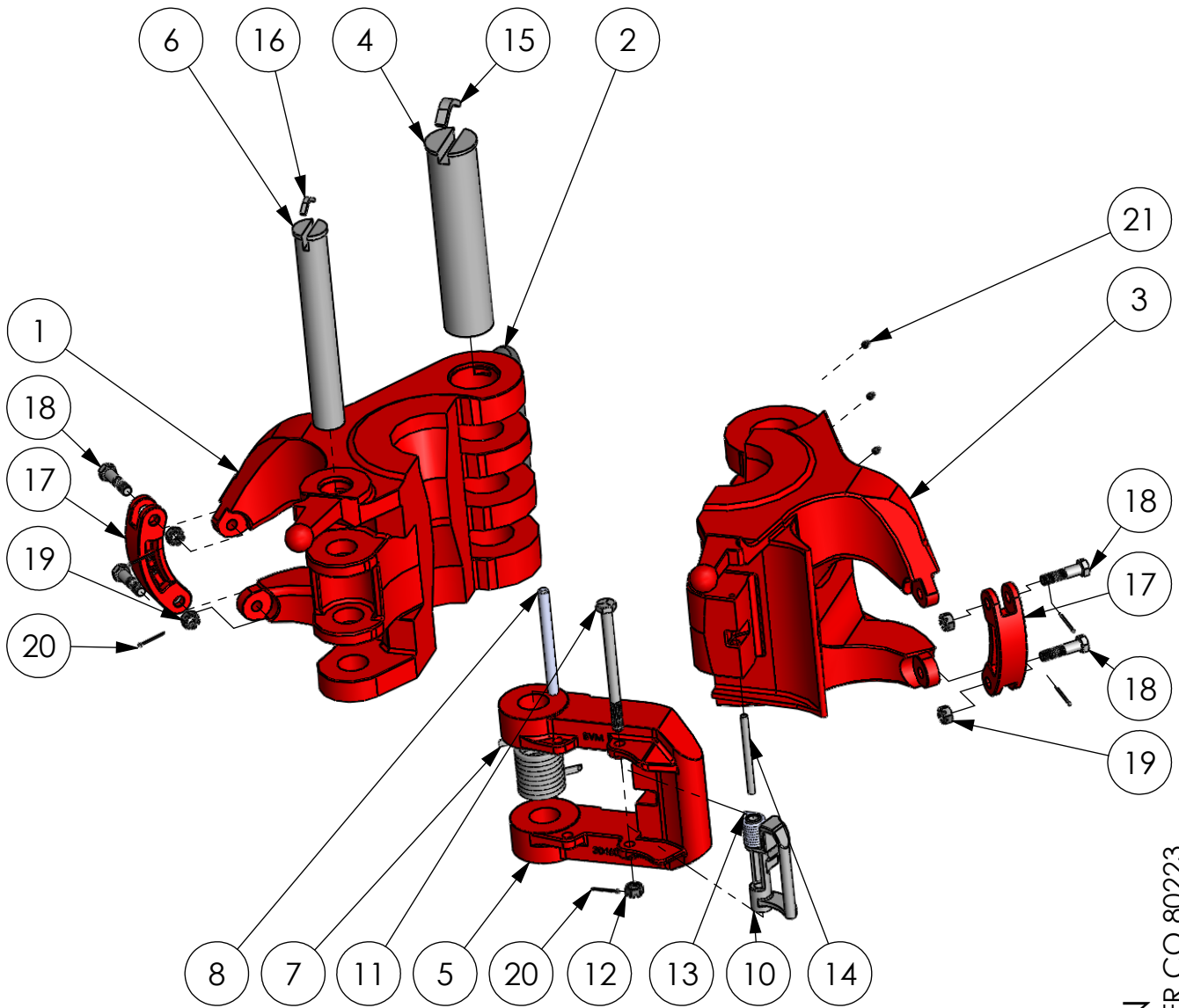

BVM CORPORATION
430 S. NAVAJO STREET, DENVER CO 80223
PHONE: 303-975-1402; FAX: 303-975-0981
www.bvmcorp.com; sales@bvmcorp.com

BVM G SERIES ELEVATOR

REF NO.	DESCRIPTION	NO. REQ	MG 100T 30157-**	RG 150T 30156-**	MGG 250T 35005-**	MGG 175T 13884-**	GG 350T 31068-**	HGG 500T 70013-**
1	BODY	1	11761-1	23567-2	34904	13884L	31069-1	70013L
2	BODY BACK HANDLE	1	--	--	--	--	--	70013LH
3	DOOR	1	11762-1	23568-2	34905	13884R	31070	70013R
4	HINGE PIN	1	26813	23569	34908	13888	33998	30553
5	LATCH	1	11763	23543	34906	13151	31071	30460M
6	LATCH PIN	1	26814	23544	34907	13154	33999	30613
7	LATCH SPRING	1	11766	23546	34909	13155	18416	31228
8	LATCH SPRING STOP	1	--	23548	13185	13185	13185	31215
9	LATCH CAM	1	11581	--	--	--	--	--
10	LATCH LOCK	1	11764	13152	13152	13152	13152	13152-1
11	LATCH LOCK BOLT	1	11759-1	23553	15101	15101	15101	31138
12	LATCH LOCK BOLT NUT	1	--	6812C-00-5	6812C-00-5	6812C-00-5	6812C-00-5	6812C-00-5
13	LATCH LOCK SPRING	1	--	13188	13188	13188	13188	13188
14	DOOR LUG PIN	1	12529	23547	13190	13190	13190	31216
15	HINGE PIN RETAINER	1	--	--	34910	--	31074	30609
16	LATCH PIN RETAINER	1	8156	8156	34911	13191	32892	31525
17	LINK BLOCK	2	26817	9519	9519	9519	9519	30942
18	LINK BLOCK BOLT	4	26817-1	8145	8145	8145	8145	8145
19	LINK BLOCK NUT	4	6812C-00-5	6812C-00-5	6812C-00-5	6812C-00-5	6812C-00-5	6812C-00-5
20	COTTER PIN	5	30AB0-12-0	30AB0-12-0	30AB0-12-0	30AB0-12-0	30AB0-12-0	30AB0-12-0
21	GREASE FITTING	1	940308-1	940308-1	940308-1	940308-1	940308-1	940308-1

** = See Bore Code Charts