

BVM MANUAL TYPE "SDD" TONG 100,000 ft/lbs TORQUE

The BVM Type "SDD" Tong covers drill pipe or casing sizes from 4" through 17" OD and is rugged in design and allows the operator greater torque when needed. The tong is made from alloy steel, heat treated and magnetic particle inspected, and complies to API 7K.

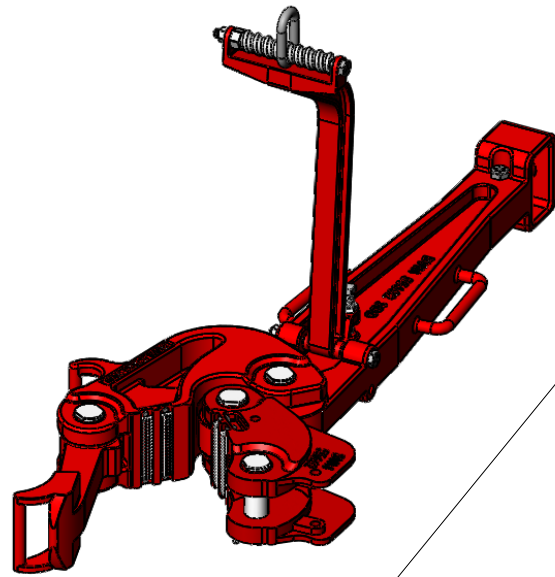

55701-1
SDD TONG
COMPLETE WITH LEVER - LESS LUG JAWS

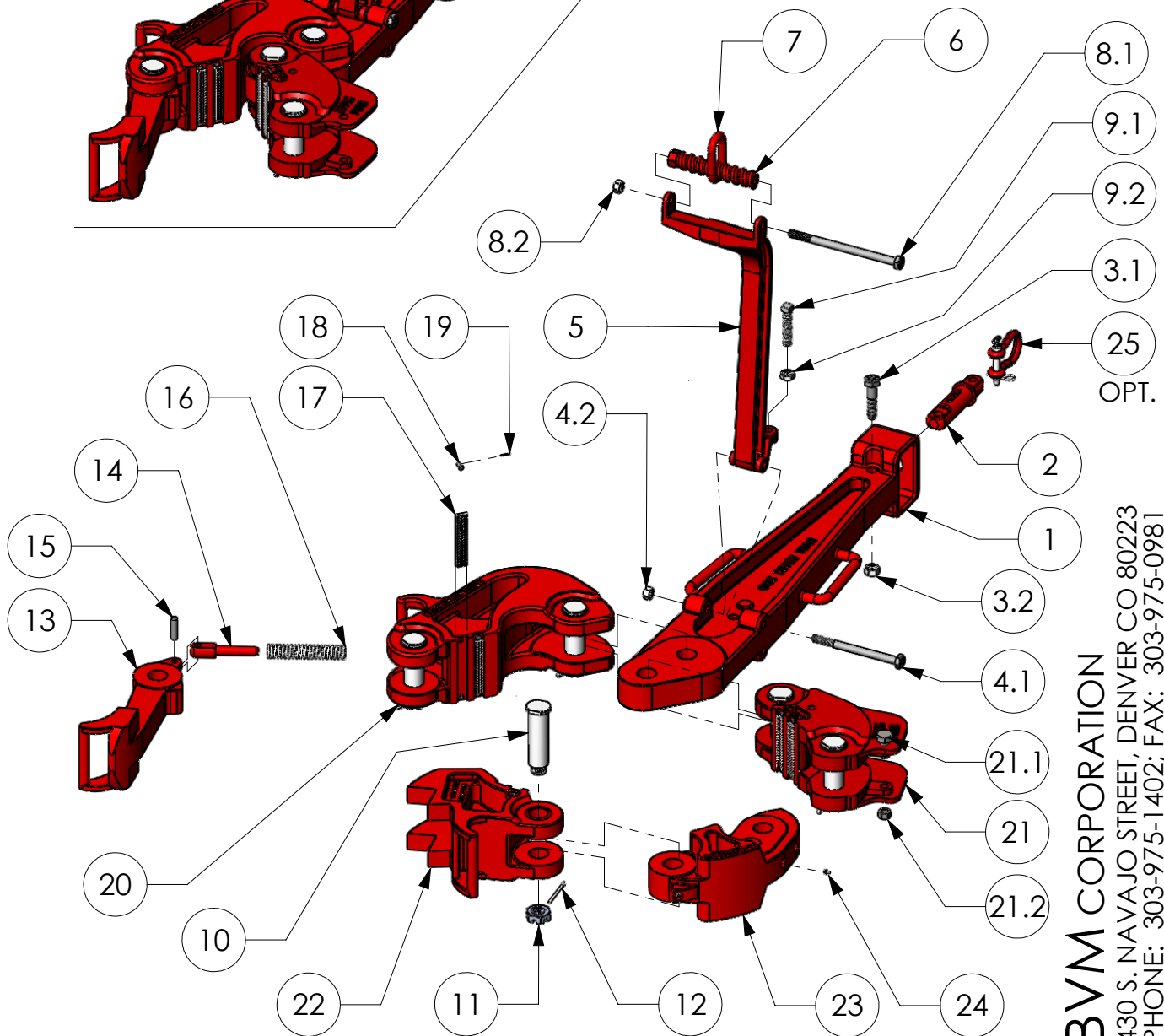

BVM CORPORATION
430 S. NAVAJO STREET, DENVER CO 80223
PHONE: 303-975-1402; FAX: 303-975-0981
www.bvmcorp.com; sales@bvmcorp.com

BVM MANUAL TYPE "SDD" TONG 100,000 ft/lbs TORQUE

ITEM NO.	DESCRIPTION	QTY REQ.	PART NO.	WEIGHT EACH (lbs)
--	TYPE SDD TONG COMPLETE WITH LEVER - LESS LUG JAWS	--	55701-1	528.0
--	LEVER ASSEMBLY - INCLUDES ITEMS 1, 2, 3, 4, 24 (2X)	--	55652-1	225.5
1	LEVER	1	55652	215.8
2	TONG LINE PIN	1	67269	6.9
3	TONG BOLT & NUT	1	55654	1.0
3.1	BOLT	--	1414C-32-8	0.8
3.2	LOCKNUT	--	6214C-00-8	0.1
4	HANGER BOLT & NUT	1	67263-4	1.2
4.1	BOLT	--	1412C-76-5	1.0
4.2	LOCKNUT	--	6212C-00-5	0.1
--	HANGER ASSEMBLY - INCLUDES ITEMS 5, 6, 7, 8, 9	--	67264-1	44.0
5	HANGER	1	67264	37.4
6	HANGER BALANCING SCREW	1	67258	3.0
7	SUSPENSION RING	1	67267	1.5
8	HANGER BALANCING BOLT & NUT	1	67266	1.2
8.1	BOLT	--	1412C-96-5	1.0
8.2	LOCKNUT	--	6212C-00-5	0.1
9	ADJUSTMENT BOLT & NUT	1	67268	1.0
9.1	BOLT	--	8014C-32-5	0.7
9.2	HEX JAM NUT	--	6114C-00-5	0.2
10	HINGE PIN - THREADED	4	55655	6.5
11	HINGE PIN NUT	4	55656	0.3
12	COTTER PIN	4	30050-24-0	0.1
--	LATCH ASSEMBLY - INCLUDES ITEMS 13, 14, 15, 16, 24	--	55658-1	58.0
13	LATCH	1	55658	55.5
14	LATCH SPRING PLUNGER	1	55659	1.7
15	LATCH SPRING PLUNGER PIN	1	55660	0.1
16	LATCH SPRING	1	55661	1.0
17	TONG DIE	AR	67430	1.0
18	CLEVIS PIN	AR	55060-06-0*	0.1
19	COTTER PIN	AR	30020-06-0	0.1
--	LONG JAW ASSEMBLY - INCLUDES ITEMS 17(2X), 18 (4X), 19 (4X), 20	--	55665-1	216.5
20	LONG JAW	1	55665	214.6
--	SHORT JAW ASSEMBLY - INCLUDES ITEMS 17 (2X), 18 (4X), 19 (4X), 21	--	55662-1	93.5
21	SHORT JAW	1	55662	91.8
21.1	BOLT	1	1412C-56-5	0.6
21.2	LOCKNUT	1	6212C-00-5	0.1
22	-A LUG JAW 4" TO 8 1/2"	1	55702	138.9
	-B LUG JAW 8 1/2" TO 12"	1	55703	100.6
	-C LUG JAW 12" TO 15"	1	55704	142.7
	-D LUG JAW 15 3/4"	1	55705	157.9
	-E LUG JAW 16" TO 17"	1	55706	165.2
23	HINGE JAW (REQUIRED FOR JAW SIZES 8 1/2" TO 17")	1	55707	95.6
24	GREASE FITTINGS	AR	940308-1	0.1
25	CLEVIS ASSEMBLY (OPTIONAL)	--	45711	2.0
--	TONG PULL BACK (OPTIONAL)	--	45726	3.0

AR = AS REQUIRED

* = 55060-06-0 OR 55060-08-0 DEPENDING ON CASTING