

**BVM Corporation**  
**Hinged Casing Spider and Bushings**  
**13 3/8" to 36", 200 Ton / 250 Ton**

Part number: \_\_\_\_\_

Serial Number: \_\_\_\_\_

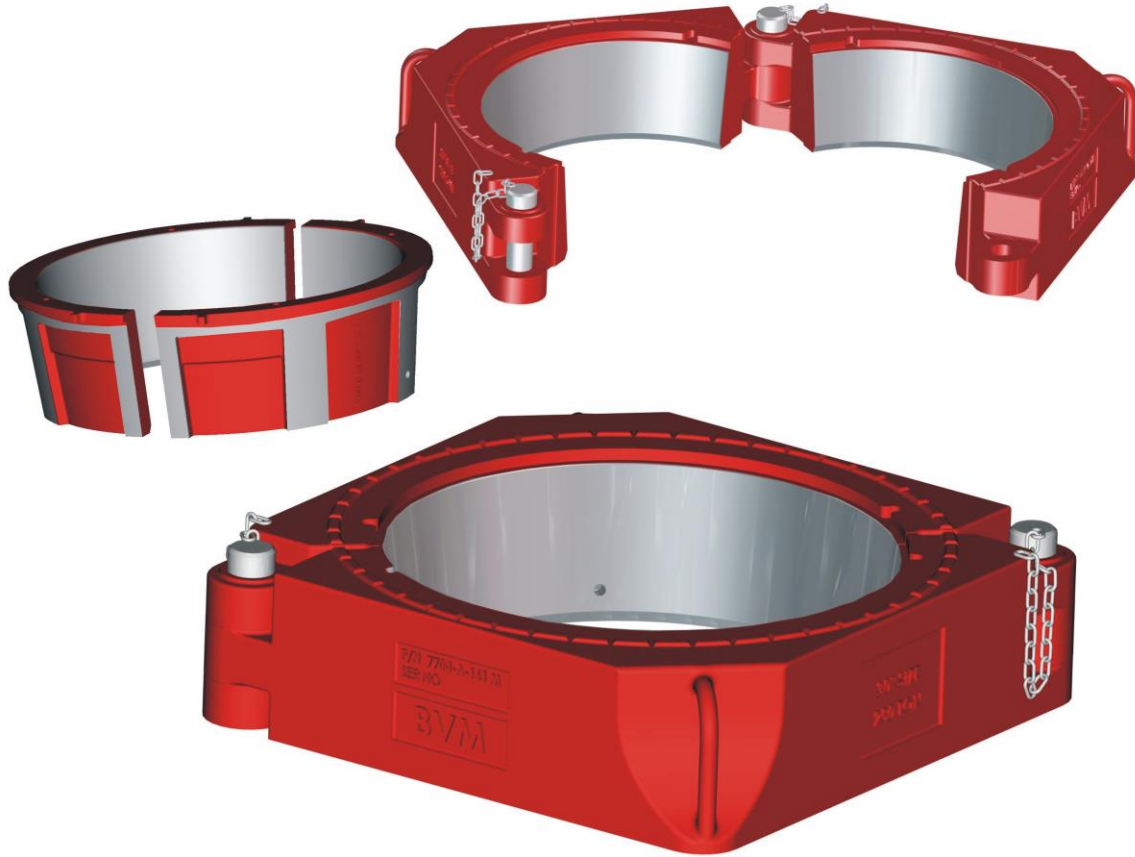

**Hinged Casing Spider and Bushings**

**Safety**

***CAUTION: Practice safety in the operation and maintenance and use only approved safety methods, materials and tools. Keep hands away from any pinch point or undesignated areas; use only the provided handles for operating the slip.***

**WARNING: Hinged Casing Spiders and Bushings which have experienced wear beyond established wear criteria set by OEM, or are found to have cracks must be replaced.**

**WARNING: Only original BVM parts may be used. Hinged Casing Spiders and Bushings are produced from cast alloy heat treated steel and must not be welded in the field. Improper welding can cause cracks and brittleness in heat-affected areas which can result in dramatic weakening of the part and possible failure. Repairs involving welding and/or machining should be performed only by a BVM authorized repair facility. Using Hinged Casing Spiders and Bushings that has been improperly welded or repaired is dangerous.**

**NOTE: The owner and user together with the manufacturer should jointly develop and update inspection, maintenance, repair and remanufacture procedures consistent with equipment application, loading, work environment, usage and other operational conditions. These factors may change from time to time as a result of new technology, equipment history, product improvements, new maintenance techniques and changes in service conditions.**

### **Description:**

Hinged Casing Spiders and Bushings will meet most types of casing handling operations. They can be placed on the rotary table, mounted on a platform that replaces the rotary table, or supported on cribbing.

The Hinged Casing Spiders and Bushings are adaptable to running casing when casing will not pass thru the rotary table, when accessory production or cementing equipment will not clear the closed spider or the rotary table, or when it is preferred not to place heavy casing string loads on rotary table bearings.

The BVM Hinged Casing Spiders and Bushings have a working capacity of either 200 Tons or 250 Tons – depending on the model with a safety factor of 3 to 1 based on the minimum yield of the material. The Hinged Casing Spider, being split and retained as an assembly by removable hinge pins which can be opened from either side by pulling one of the hinge pins. The hinge pins are attached to the body by safety chains to avoid being dropped in the well.

Spider bushings are also split and are retained against displacement and held in place by both keys and bolts.

Spider bushings for handling casing 9” OD and larger are tapered at 3 inches per foot and use UC3 Casing Slips with a matching taper. Bushings for handling 8 5/8 inch OD and smaller Casing have a tapered bore suited to API standard Rotary Slips.

## Cleaning and Lubrication

Clean the inside taper of the drilling bowls to remove any abrasive material. Lubricate the inside taper of the drilling bowls frequently with grease to prevent slips from sticking in the bowls. Warning: Never use pipe dope to grease the back of the slips.

## Dressing Slips and Insert Bowls

The slips and bowl ID should be dressed as well as cleaned to prevent sticking of the slips. Abrasive materials in the drilling mud can cause horizontal lines of wear in the mating surfaces of the slips and bowls. Dressing these surfaces, using an up and down motion with emery cloth will result in the grain of the two parts running with each other to significantly reduce friction.

## Hinged Casing Spiders and Bushings Inspection

Regular inspection of the Hinged Casing Spiders should include examination of the bodies, hinge pins and chains for cracks or damage. Cracked or bent hinge pins must be replaced. Broken, loose or missing safety chains must be replaced or securely reattached before being used. The tapered bore of the spider or bushing should be checked with a straight edge and if visibly worn, must be replaced. Any visible cracks in the tapered surface, the hinge pin bosses or on the outside of the body or bushing would require re-examination by a factory authorized repair facility or replaced before re-use.

## Wear Data

Max Clearance 'A'	
Hinge Pin	0.05 in

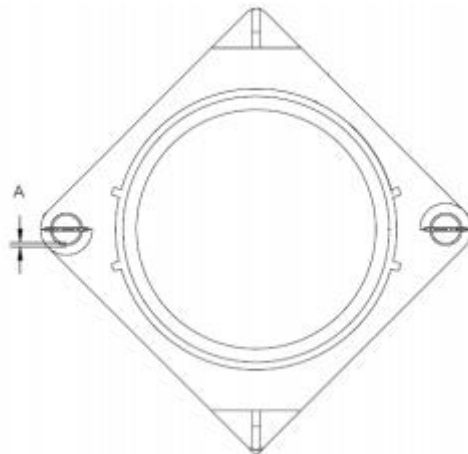

### Critical areas drawings

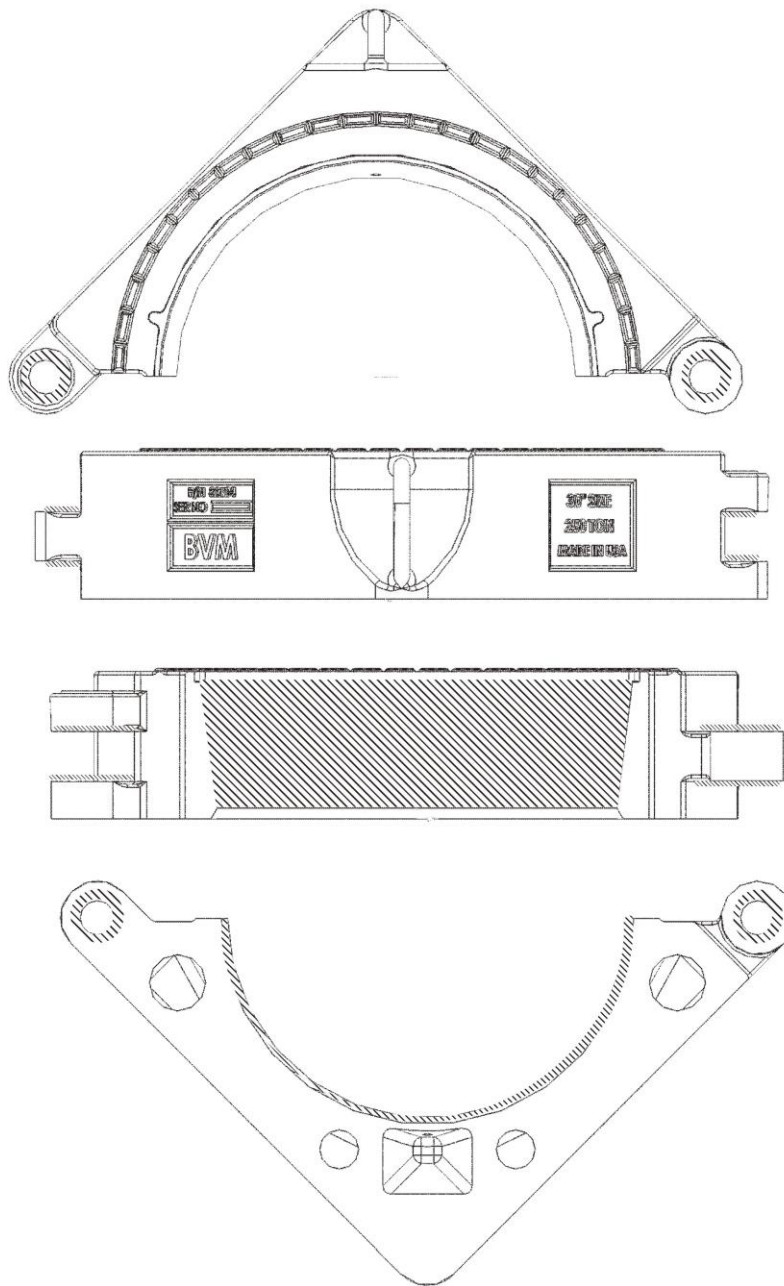

**Hinged Casing Spider Wear Areas**

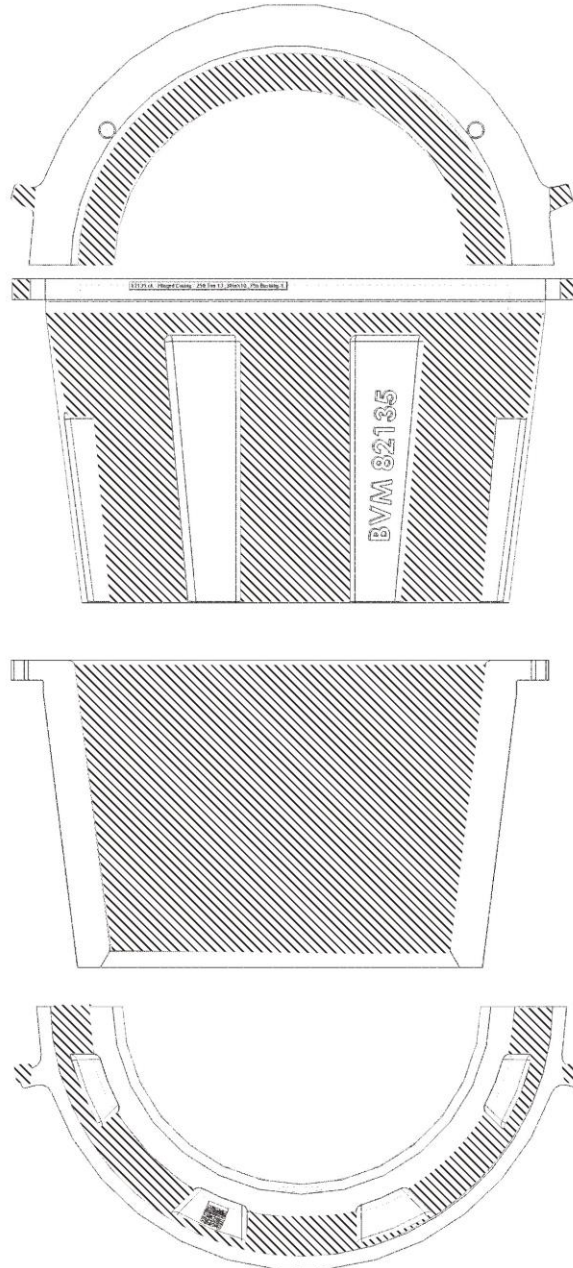

### **Spider Bushing Wear Areas**

**Assembly Drawing and List of Parts** – see attachment.